



# Scanning Transparencies



## Step 1: Prepare scanner

- Make sure that the scanner is powered on. If the light near the silver “Start” button is green, the scanner is on.  
 Start
- If there is no power light, press the grey power button once. The power button is located on the lower left-hand side of the front of the scanner.  
 Power
- Lift the lid and gently clean the document glass with an anti-static cloth.
- Remove the white reflective **document mat** by grasping the mat by its top edge and sliding it upward to free the bottom edge of the mat.

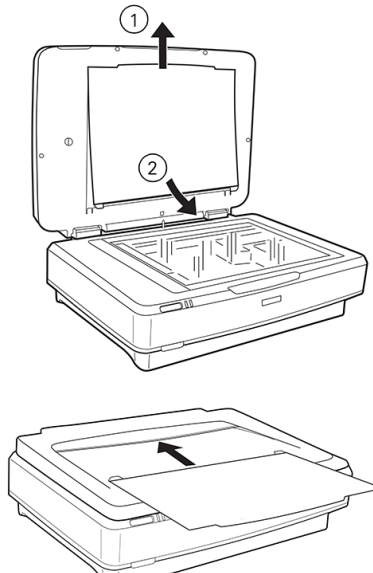

- Lower the mat slightly to free the tabs at the top edge, then remove the mat.
- Place the mat in the storage pocket located on top of the scanner.

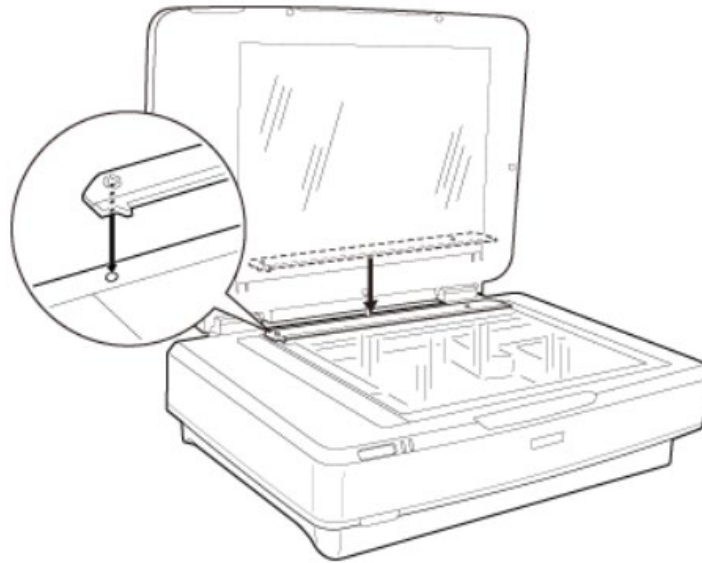

- Place the **transparency guide** onto the scanner as shown. The small protrusions on its bottom should fit snugly into the divots in the top of the scanner bed.
- **NOTE: You must use the transparency guide for your transparencies to be scanned properly.**

## Step 2: Prepare transparencies

- To scan transparencies, use the **film holder** that is appropriate to the size of your film.
- The type of **film holders** are as follows: (1) 35 mm slides, (2) 35 mm filmstrips, (3) 4 x 5 inch film, and (4) medium format (120, 220, and 6 x 12 cm) film.

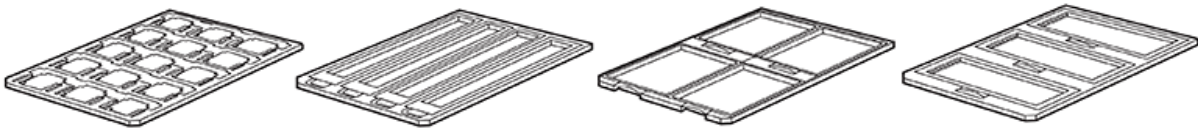

(1)

(2)

(3)

(4)

- Place the **film holder** on a flat surface. Open its cover (if it has one), then load the film with its **shiny side face-down and the emulsion layer face-up**.
  - The emulsion side will be dull, slightly convex, and appear to have small lines, bumps, or ridges when viewed at an angle. Any text in the transparency will appear backwards when viewed from the emulsion side.
  - The reflective side will be shiny, slightly concave, and smooth. Any text in the transparency will appear normally when viewing this side.

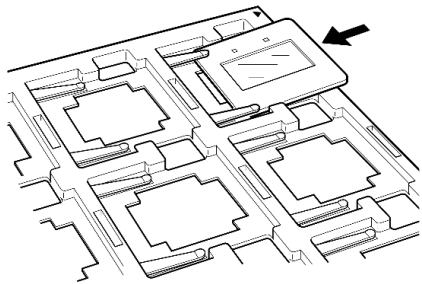

35 mm slides

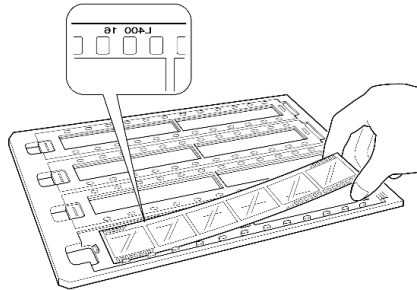

35 mm strips

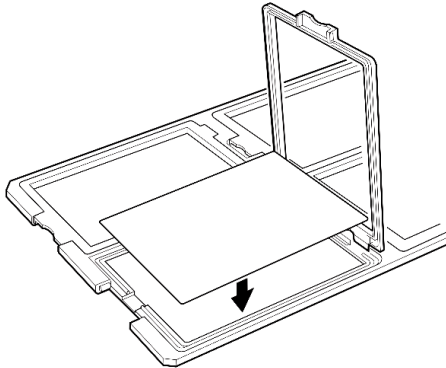

4 x 5 inch film

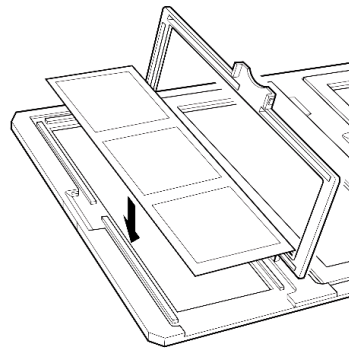

Medium format film

- **Make sure the transparency guide is in place at the back edge of the scanner glass.**
- Place the **film holder** on the document glass, aligning the arrow marks as shown.

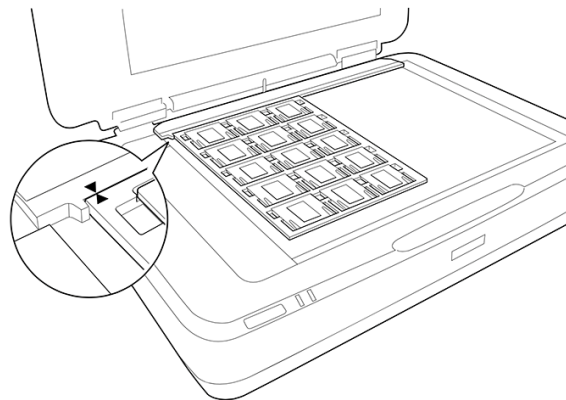

- **Close the lid.** NOTE: If the lid is not closed, you will get an error message and will be unable to scan.

### **Step 3: Make a save folder and open Epson Scan**

- On the **desktop**, either select **File → New Folder** or right-click on an empty space and choose “New Folder.”
  - Give the folder a recognizable name, such as “Scanned slides”
- Select the **Epson Scan** software from the dock at the bottom of the screen.

## Step 4: Settings and preview

- Leave **Scan Settings** at “Not Selected.”
- **Mode** should be set to “Photo Mode.”



- *Optional:* You can select **Advanced Settings** to make more detailed decisions about your image. If you are unfamiliar with scanning software, we recommend leaving these settings alone.
- **Document Source** should be set to “Transparency Unit.”
- **Document Type** should be set to the type of transparency you are scanning.
  - Use “Color Positive Film” for slides.
  - Use “Color Negative Film” for negatives in color,
  - Use “Black & White Negative Film” for black and white negatives.
  - **NOTE:** If you do not have the proper **Document Type** selected, the scanner will not recognize the images and the Thumbnail option will not function.
- Under **Image Type**, choose the option that best fits your document.
  - Use “48-bit color” for color images.
  - Use “16-bit grayscale” for black & white images.
- Use the table below to determine the recommended **Resolution** in DPI (Dots Per Inch):

Long Edge of film	Recommended DPI
35mm (slides and film strips)	2400 dpi
3”	1600 dpi
4”	1200 dpi

- Leave **Scanning Quality** set at “Standard,” or choose “High” for better quality images and much larger sized files.

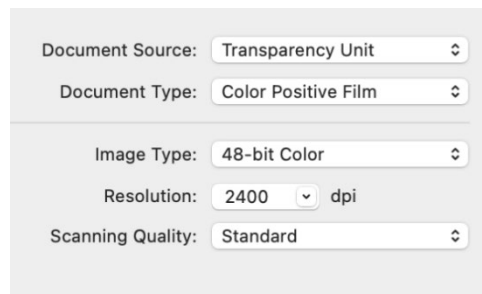

- Although you can use **Color Management** to adjust the color of your image, we recommend leaving these settings at their defaults.
- Choose your **Image Format**, TIFF or JPEG. We recommend creating TIFFs. They use more memory but will prevent image loss if you need to resize your image later in Photoshop or other photo editing software.

- Use **File Name** to give your transparencies unique names that describe what they are, e.g. “BirthdayParty1988.”
- Use **Folder** to select the “Scanned slides” folder on the desktop you created earlier so that your scanned images will be saved there.

Image Format:	TIFF
File Name:	img0002.tif
Folder:	Desktop

- Finally, select **Preview** to create a preliminary scan of your transparencies. You should hear the scanner working. Give it a few seconds.
- To see thumbnails of your images, make sure the box is checked next to the **Thumbnail** option at the top of the preview window.
  - **Note:** If you do not select the **Thumbnail** option, you will have to manually select the area within the **Preview** image to be scanned.



### Step 5: Scan

- If you wish to change anything, go back to the start of **Step 4** to adjust the settings, then select **Preview** again to review your images before finalizing the scan. If the preview of your transparencies appears correct, select **Scan** to finalize the images.
- Be patient while the scanner completes its task. This can take a few minutes, especially scans set at high DPI.
- A window with the folder where you saved your images will pop up. You can select your files and rename them at this point.
- If you have more transparencies to scan, return to **Epson Scan** and start over at **Step 2**.

### Step 6: Copy files to your drive and finish up

- If you are done:
  - Remove the **film holder** and **transparency guide** from the scanner bed.
  - Remove your transparencies from the **film holder**.
  - Reattach the white **document mat** to the underside of the scanner’s lid.
- Connect your USB storage device to the USB hub.
- Drag the “Scanned slides” folder you created on the desktop onto your storage device to copy your images.
  - Wait until they have finished copying.
- Safely eject your device from the computer by dragging its disk image to the eject icon (trash can) on the bottom of the desktop. Or you can click on the drive and select **File → Eject**.



**Don’t forget your transparencies and storage device!**

